

**DE**

### **Anleitung für Montage**

Slide-Compact Schiebetür vor der Wand

**EN**

### **Instructions for Fitting**

Slide Compact sliding door in front of the wall

**FR**

### **Instructions de montage**

Porte coulissante Slide Compact devant le mur

**ES**

### **Instrucciones de montaje**

Puerta corredera Slide Compact delante de la pared

**RU**

### **Руководство по монтажу**

Раздвижная дверь Slide Compact перед стеной

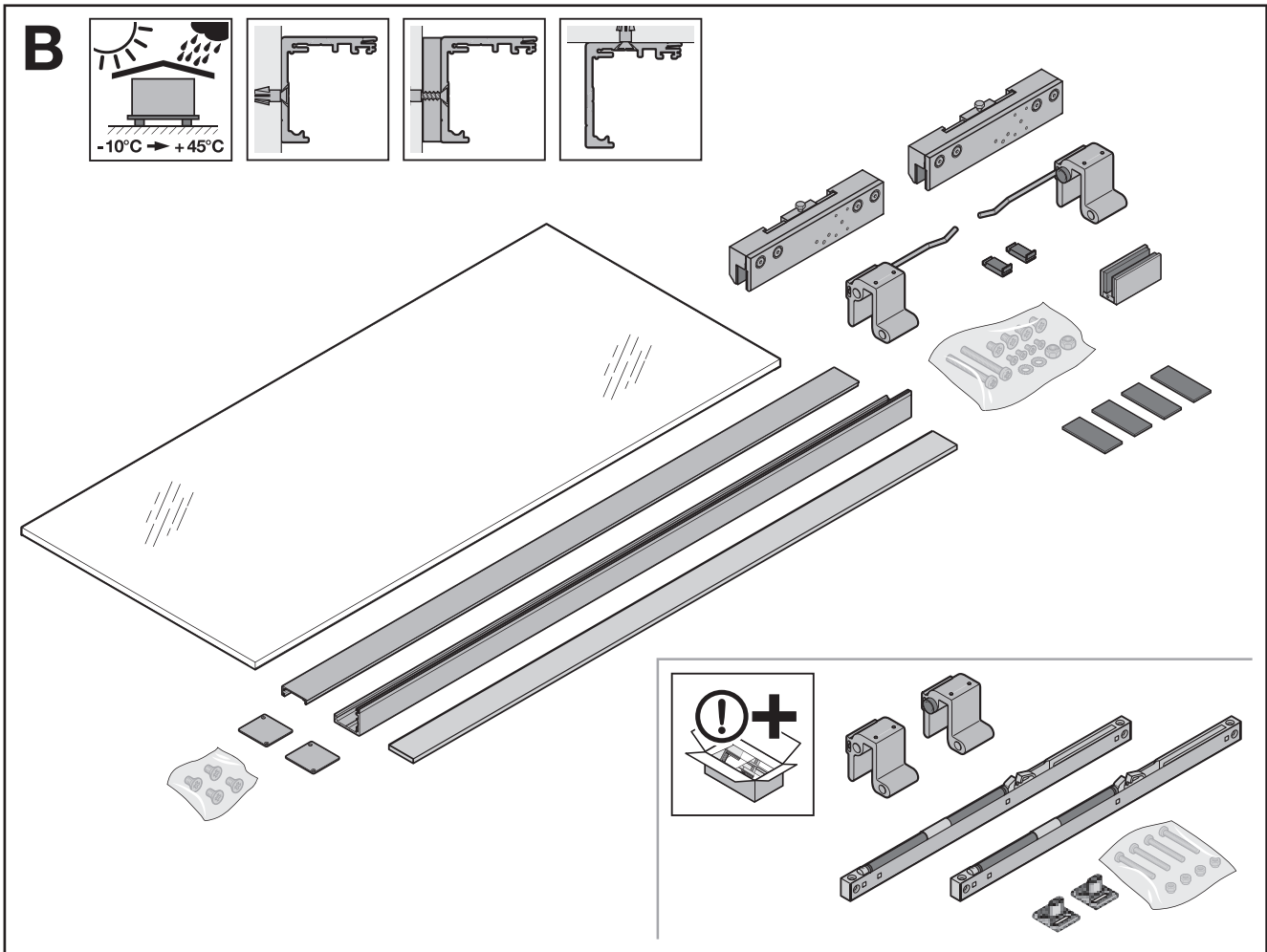
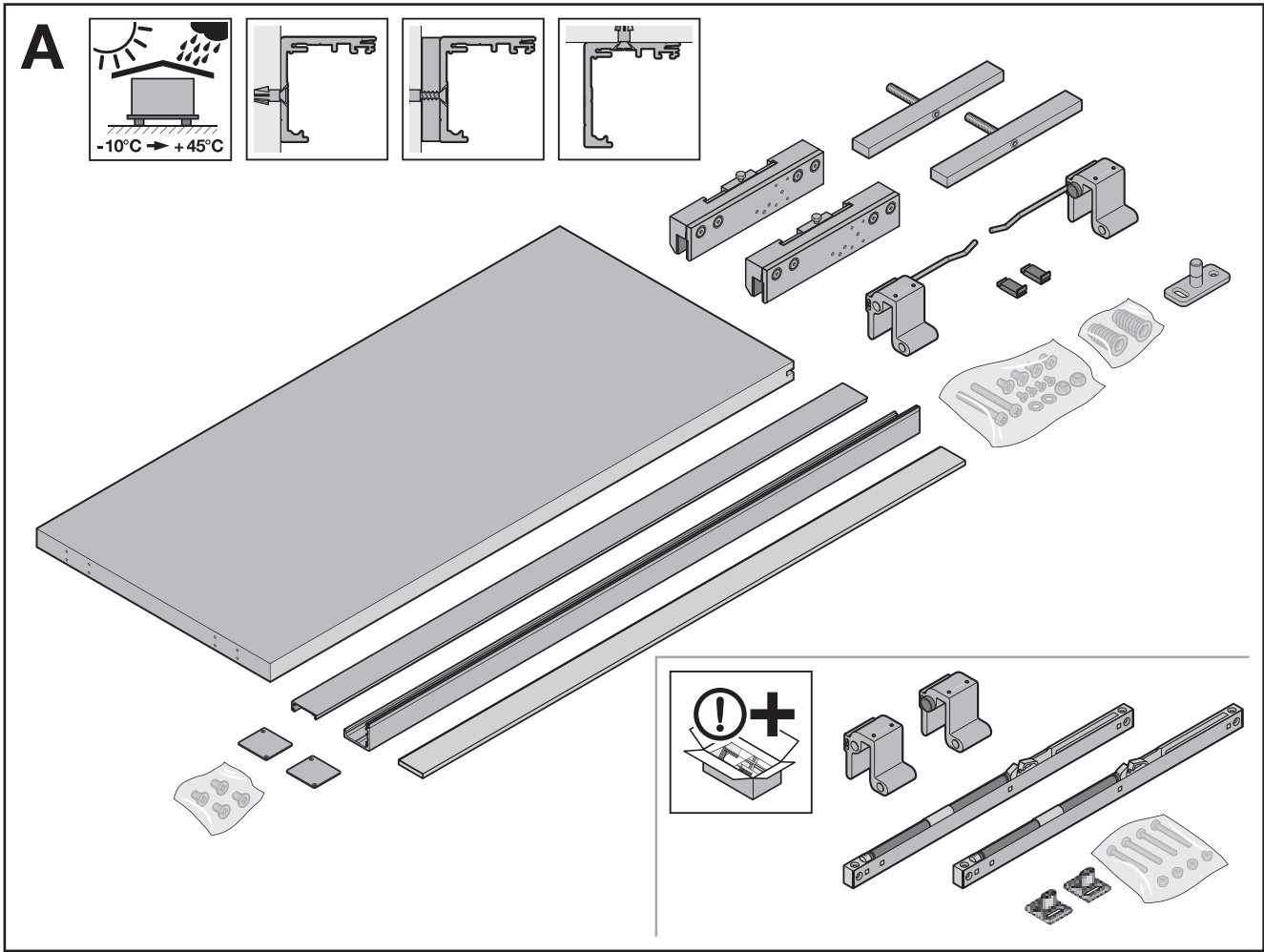

<b>DEUTSCH</b> .....	<b>4</b>
<b>ENGLISH</b> .....	<b>6</b>
<b>FRANÇAIS</b> .....	<b>8</b>
<b>ESPAÑOL</b> .....	<b>10</b>
<b>РУССКИЙ</b> .....	<b>12</b>



.....	<b>14</b>
-------	-----------

**Table of Contents**

**A, B** Articles supplied .....2  
**C** Tools needed for fitting .....2  
**1** About these instructions.....6  
 1.1 Warnings used.....6  
 1.2 Symbols used.....6  
 1.3 Abbreviations used.....7  
**2** Fitting instructions.....7  
**3** Fitting .....7  
**4** Fitting by qualified personnel / warranty .....7  
**5** Care and maintenance .....7

 .....14

Dear Customer,  
 We are delighted that you have chosen a quality product from our company.

**1 About these instructions**

Read through all of the instructions carefully: they contain important information about the product and fitting. Pay attention to and follow the instructions provided, particularly the safety instructions and warnings.





Please keep these instructions in a safe place and make sure that they are available to all users at all times. These instructions are important documentation for the building files.

Expert fitting and careful maintenance increase the performance, availability and security.

**1.1 Warnings used**

	The general warning symbol indicates a danger that can lead to <b>injury</b> or <b>death</b> . In the text section, the general warning symbol will be used in connection with the caution levels described below. In the illustrated section, an additional instruction refers back to the explanation in the text.
<b>ATTENTION</b>	
Indicates a danger that can lead to <b>damage</b> or <b>destruction of the product</b> .	

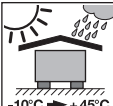
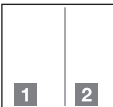
**1.2 Symbols used**

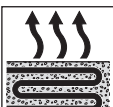
-  Important advice to prevent injury to persons and damage to property
-  Correct arrangement or activity
-  Non-permissible arrangement or activity
-  Protection against weather
-  Indicates steps in the illustrated section that must be performed in sequence.
-  Inspect
-  Floor heating system

Dissemination as well as duplication of this document and the use and communication of its content are prohibited unless explicitly permitted. Noncompliance will result in damage compensation obligations. All rights reserved in the event of patent, utility model or design model registration. Subject to changes.





See text section

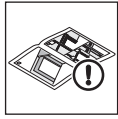

See illustrated section



See separate fitting instructions

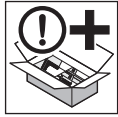

Optional

### 1.3 Abbreviations used

OFF	Finished floor level
mm	All dimensions in the illustrated section are in mm

## 2 Fitting instructions

- ▶ **Check that the individual parts are free of faults and complete and check the dimensions before assembling the parts.**
- ▶ **Check the installation situation**
  - Is the wall type suited for the fitting of the door?
  - Must the finished level of the floor be considered (metre line)?
  - Is the opening sense correct?
  - Do building regulations need to be observed?
  - Is the necessary on-site fitting material available, e.g. suitable screws for the existing wall?

#### NOTE

Processed goods cannot be exchanged!

## 3 Fitting

If the sliding door is fitted in combination with a frame, please observe the instructions for frame fitting.

## 4 Fitting by qualified personnel / warranty

The supplied products may only be fitted and put into operation by qualified personnel. We do not provide any warranty, as fitting is outside of our sphere of influence. These fitting instructions only provide recommendations, as there are several possibilities for professional and correct fitting. No legal claims can be derived from recommendations.

When cleaning glass, you should use clean water and work over the entire surface to prevent cloudiness or scouring effects due to dirt particles. Clean, soft sponges, rags, cloths, leather and rubber wipers are suitable cleaning tools. Wipe dry with a clean, dry cloth.

Putting the door into operation is prohibited until it has been established that the door has been installed in accordance with our specifications and its function

has been properly tested. A product's declaration of performance becomes invalid if an alteration to the product is carried out without consultation with us.

Wood is a natural product with individual characteristics and nuances. It reacts to changes in air humidity, amongst others. The door and frame should be subjected to as few fluctuations in humidity as possible. We therefore advise against fitting in rooms with more than 60 % relative air humidity (take note of humidity in new buildings).

## 5 Care and maintenance

A slightly damp cloth, chamois or a lint-free microfibre cloth without using special detergents is enough to maintain the high-quality surfaces of doors and frames. This allows normal household dirt (e.g. fingerprints or water splashes) to be easily removed. Use lukewarm water with a squirt of washing-up liquid for stubborn dirt. Then dry off well. Do not use any abrasive or caustic solvent-based detergents!

All important functional parts must be visually inspected on a regular basis (min. 1 × annually) for fastening and function. Identified defects (e.g. loose screws, damaged or missing seals, incorrectly set or stiff hinges) must be promptly addressed.

Please ask your dealer for further processing, maintenance and care instructions and for certificates and verifications.

## Table des matières

A, B	Articles fournis.....	2
C	Outils nécessaires au montage.....	2
1	<b>A propos de ce mode d'emploi</b> .....	8
1.1	Consignes de sécurité utilisées.....	8
1.2	Symboles utilisés.....	8
1.3	Abréviations utilisées.....	9
2	<b>Spécifications de montage</b> .....	9
3	<b>Montage</b> .....	9
4	<b>Pose par un personnel qualifié / Garantie</b> .....	9
5	<b>Entretien et maintenance</b> .....	9



.....14

Cher client,  
Nous vous remercions d'avoir opté pour un produit de qualité de notre société.

## 1 A propos de ce mode d'emploi

Lisez attentivement et entièrement les présentes instructions. Elles contiennent d'importantes informations concernant ce produit et son montage. Veuillez en particulier respecter et suivre toutes les consignes de sécurité et mises en garde.

Conservez précieusement les présentes instructions et assurez-vous que tous les utilisateurs puissent les consulter à tout moment. Ces instructions constituent un document important pour le dossier de construction.

Un montage approprié et une maintenance soignée améliorent les prestations, la disponibilité et la sécurité de l'installation.

### 1.1 Consignes de sécurité utilisées



Ce symbole général d'avertissement désigne un danger susceptible de causer des **blessures** ou la **mort**. Dans la partie texte, le symbole général d'avertissement est utilisé en association avec les degrés de danger décrits ci-dessous. Dans la partie illustrée, une indication supplémentaire renvoie aux explications du texte.

#### ATTENTION

Désigne un danger susceptible d'**endommager** ou de **détruire le produit**.

### 1.2 Symboles utilisés



Remarques importantes pour éviter tout dommage corporel ou matériel



Disposition ou procédure correcte



Disposition ou procédure interdite

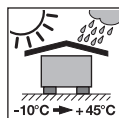

Protection contre les intempéries

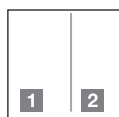

Désignation des étapes de travail de la partie illustrée devant être exécutées consécutivement



Vérification

Toute transmission ou reproduction de ce document, toute exploitation ou communication de son contenu sont interdites, sauf autorisation expresse. Tout manquement à cette règle est illicite et expose son auteur au versement de dommages et intérêts. Tous droits réservés en cas de dépôt d'un brevet, d'un modèle d'utilité ou d'agrément. Sous réserve de modifications.

**A1**

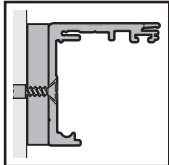
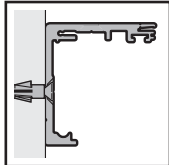
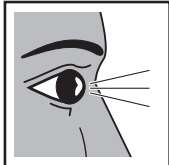

**A**

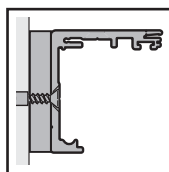
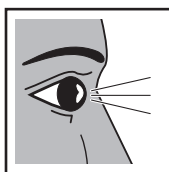
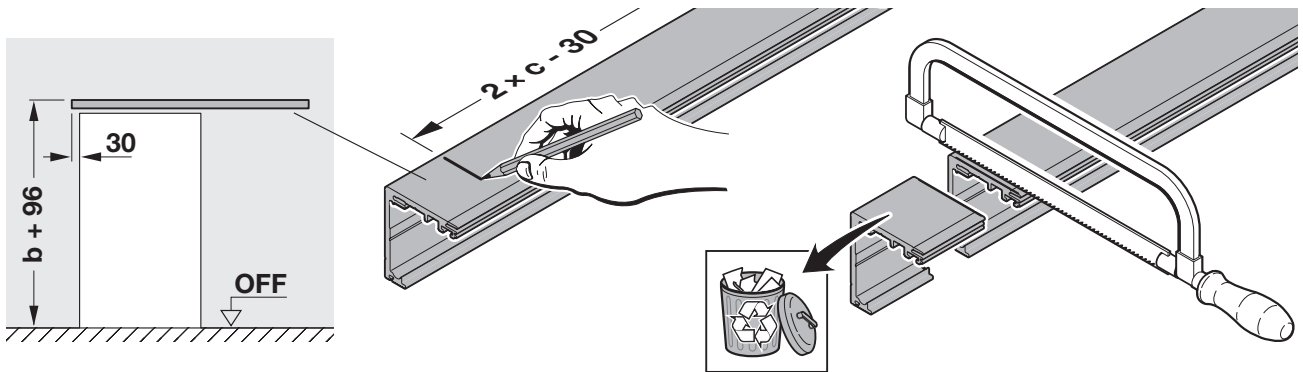
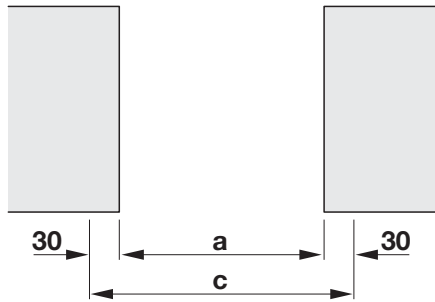
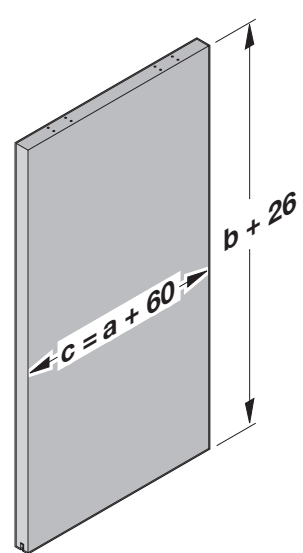
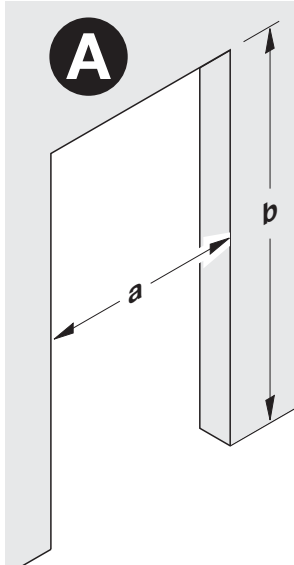

**B**

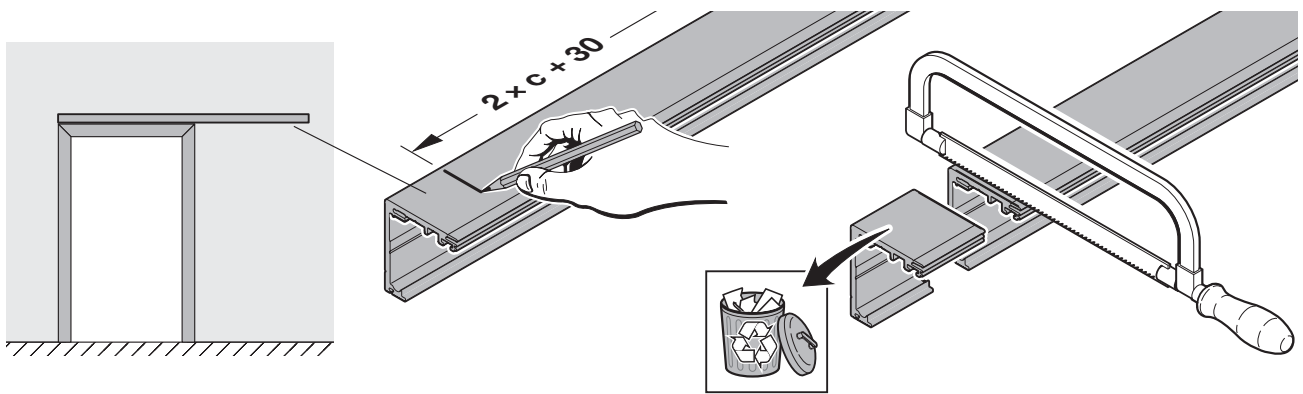
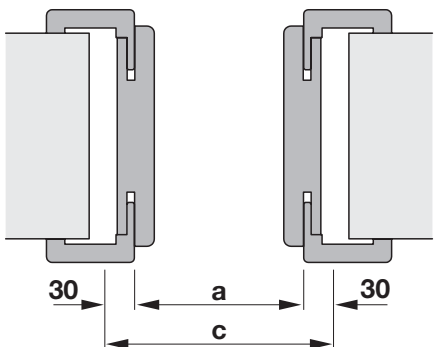
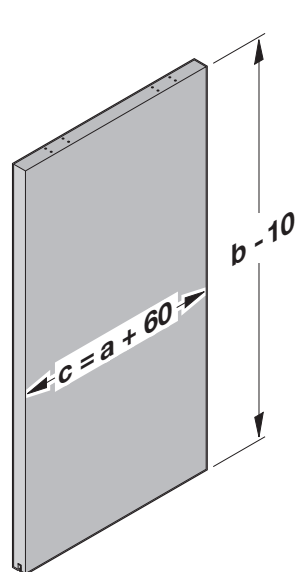
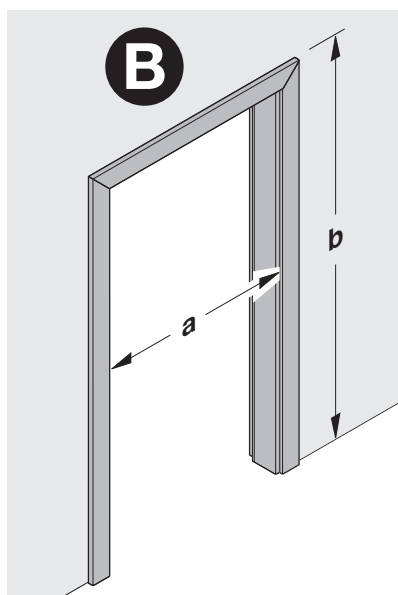

**A2**

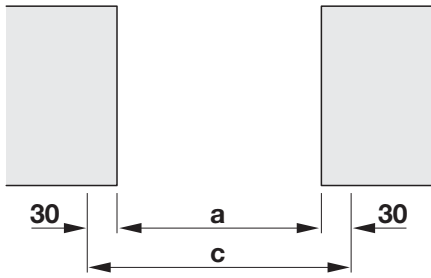
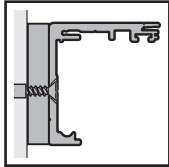
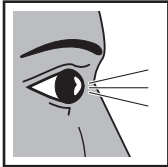

**A**

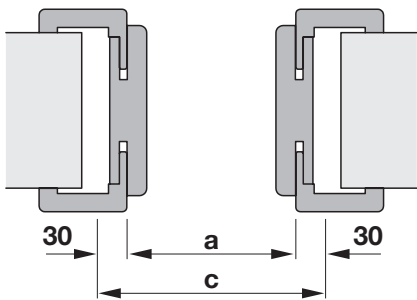
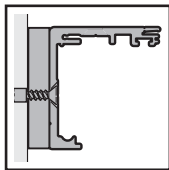
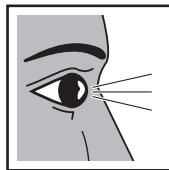
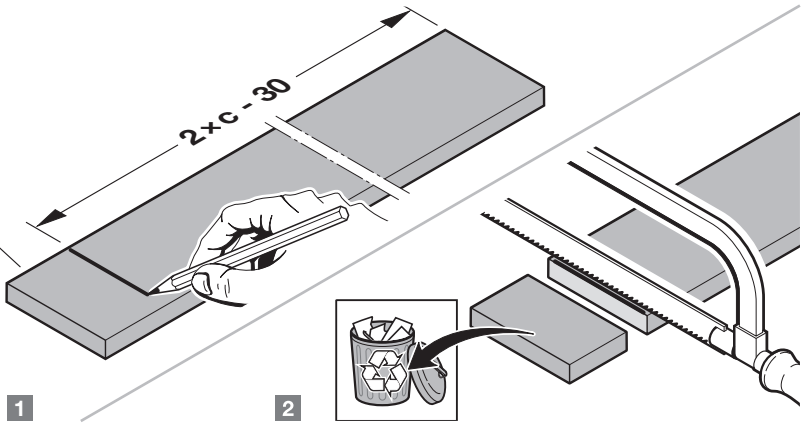
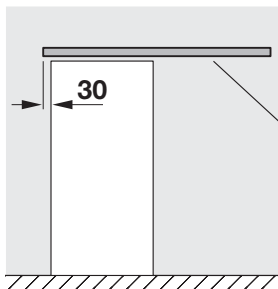
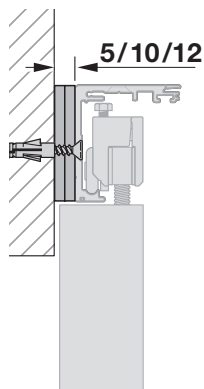
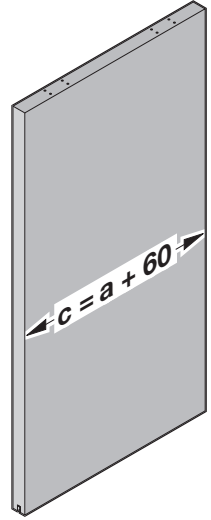
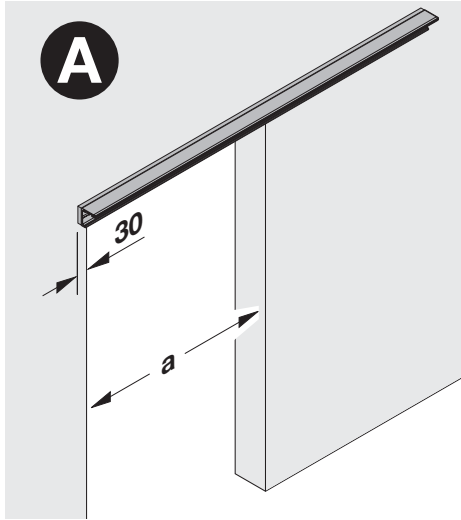

**B**

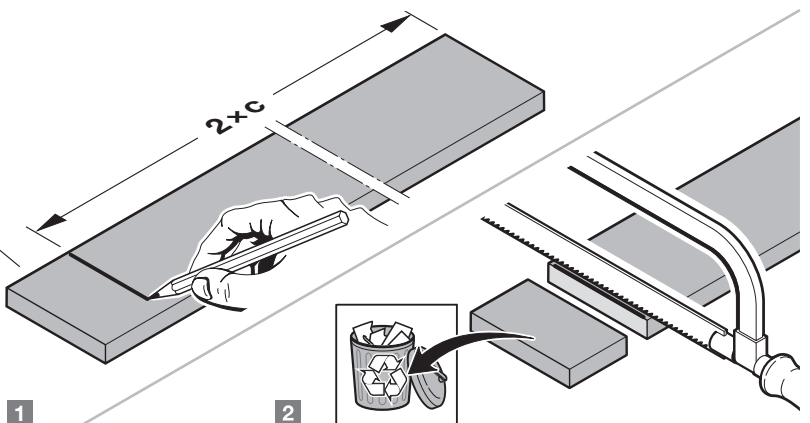
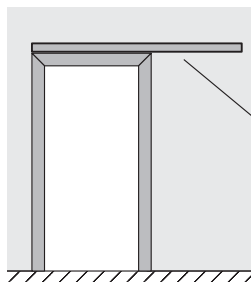
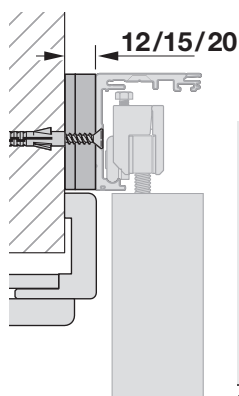
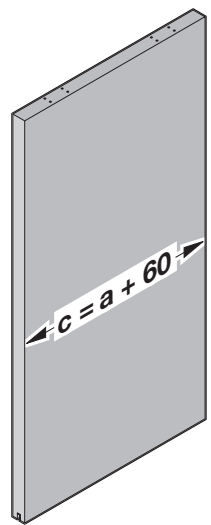
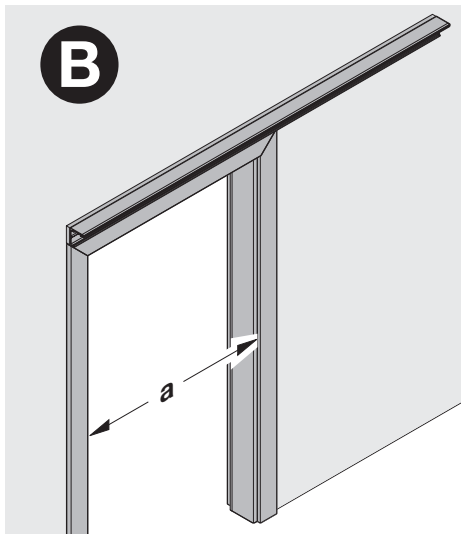

A3

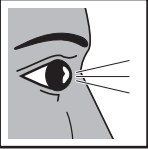

A

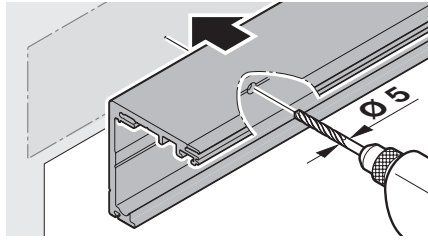

Ø5



Ø6

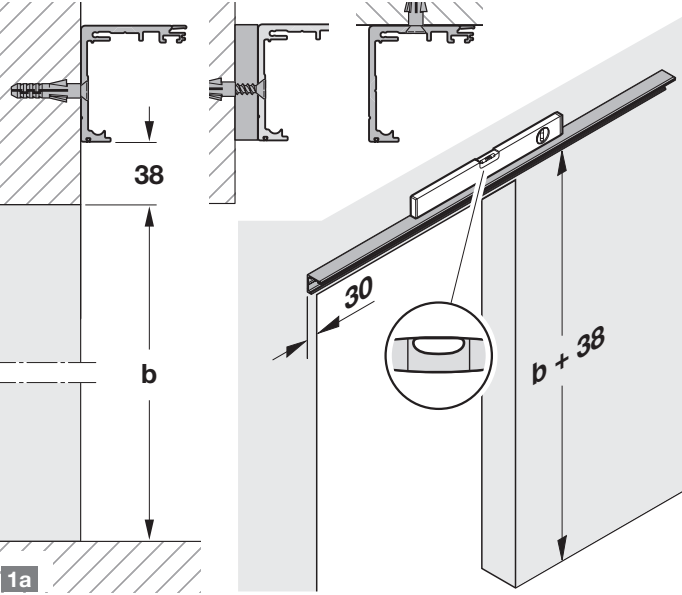
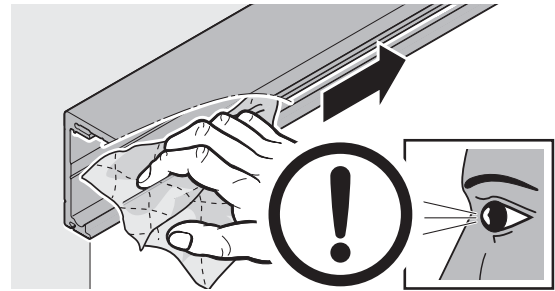
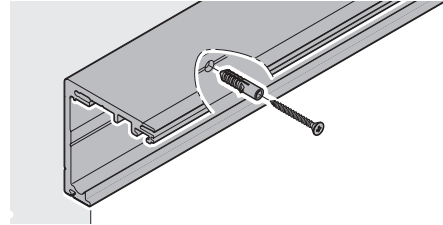
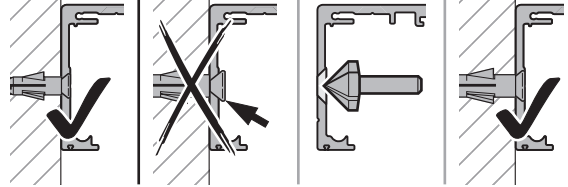

1a

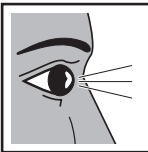

B

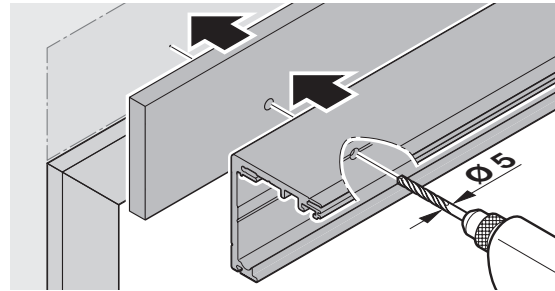

Ø5



Ø6

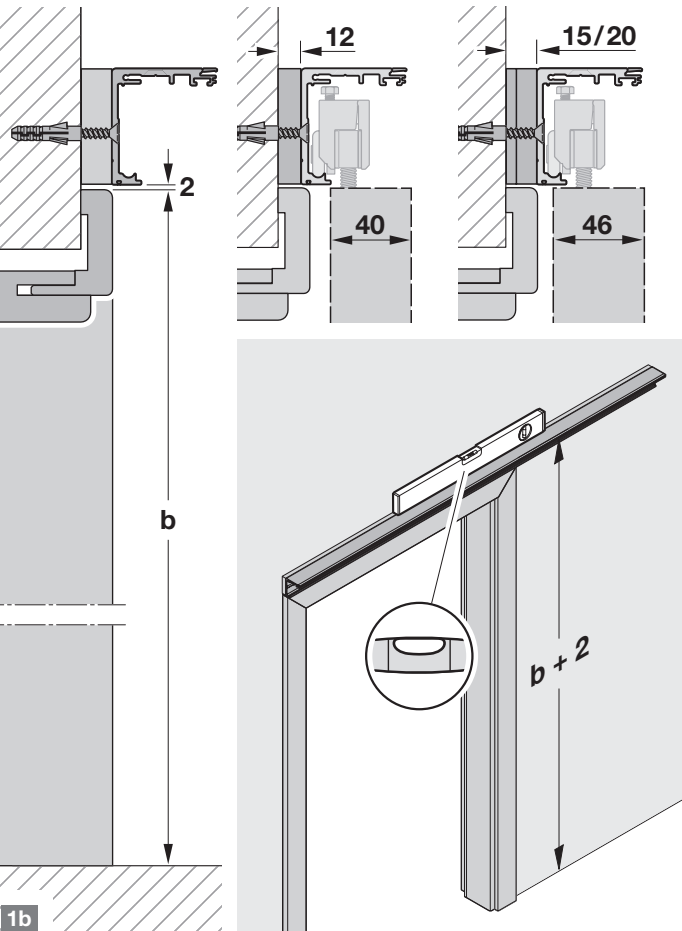
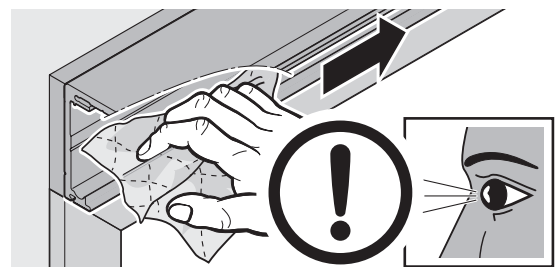
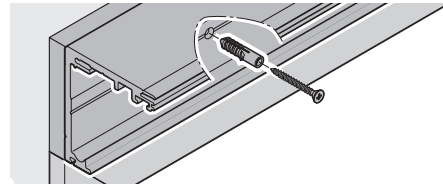
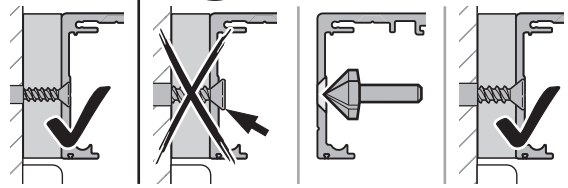

1b

**A4**

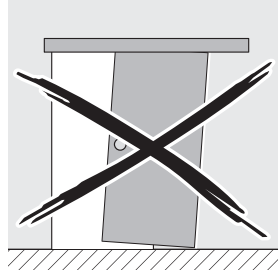
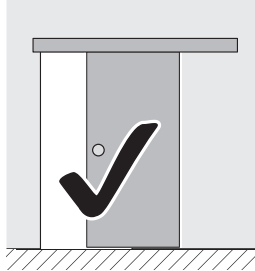
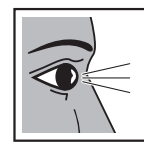
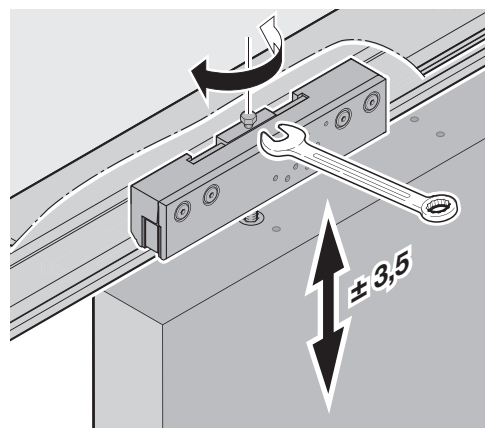
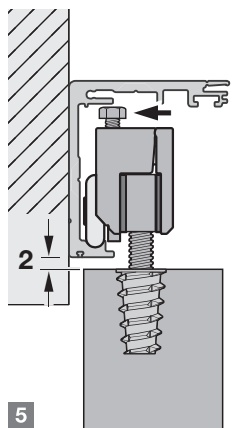
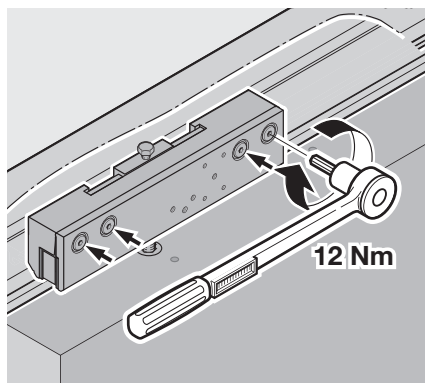
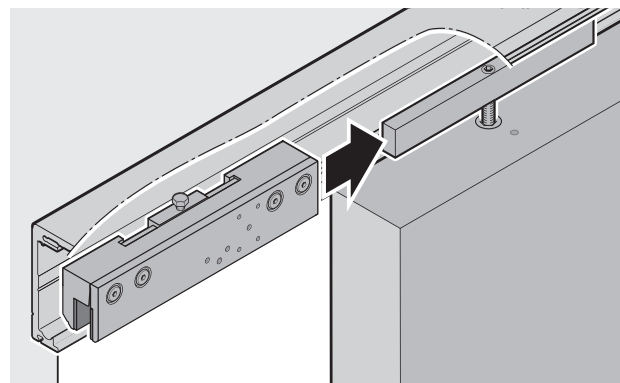
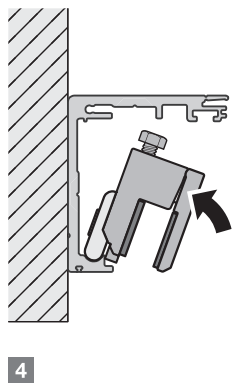
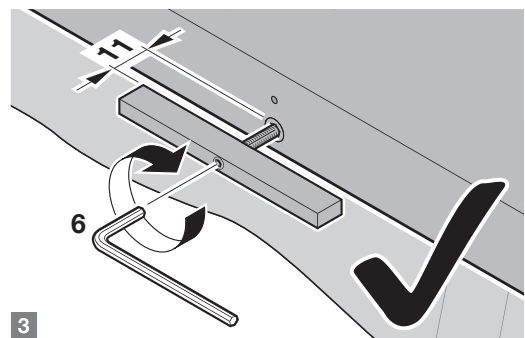
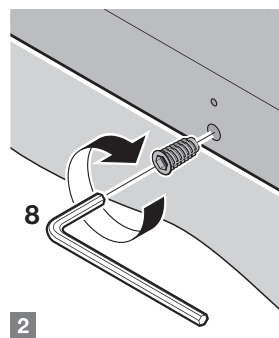
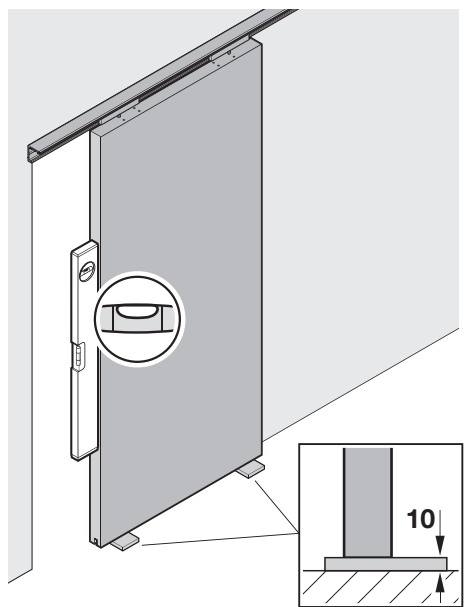
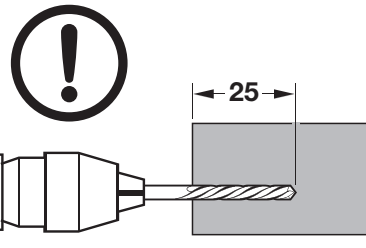
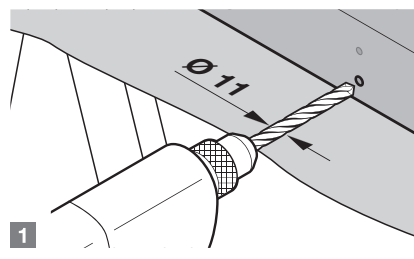
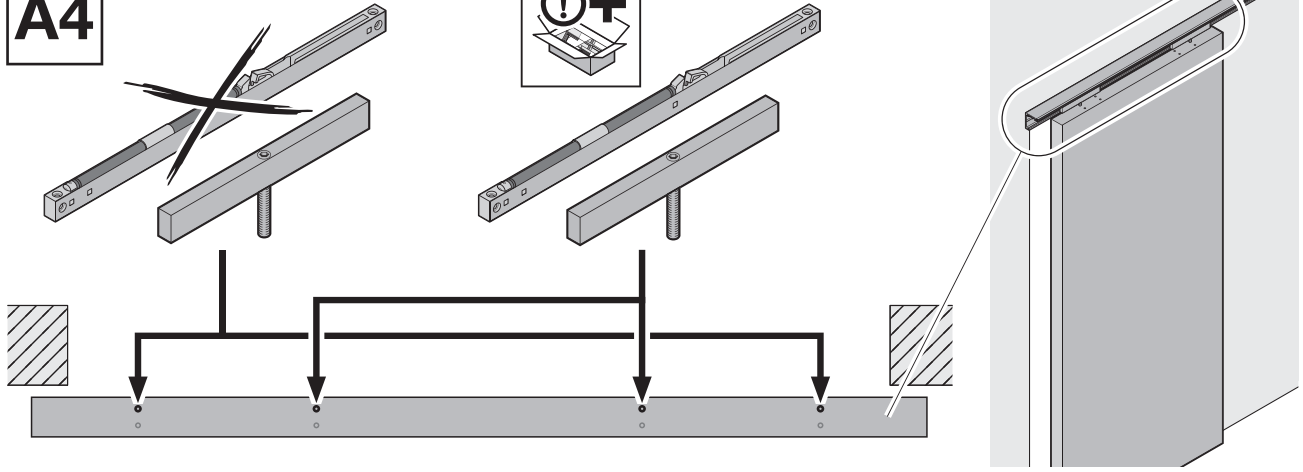
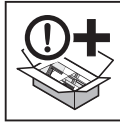

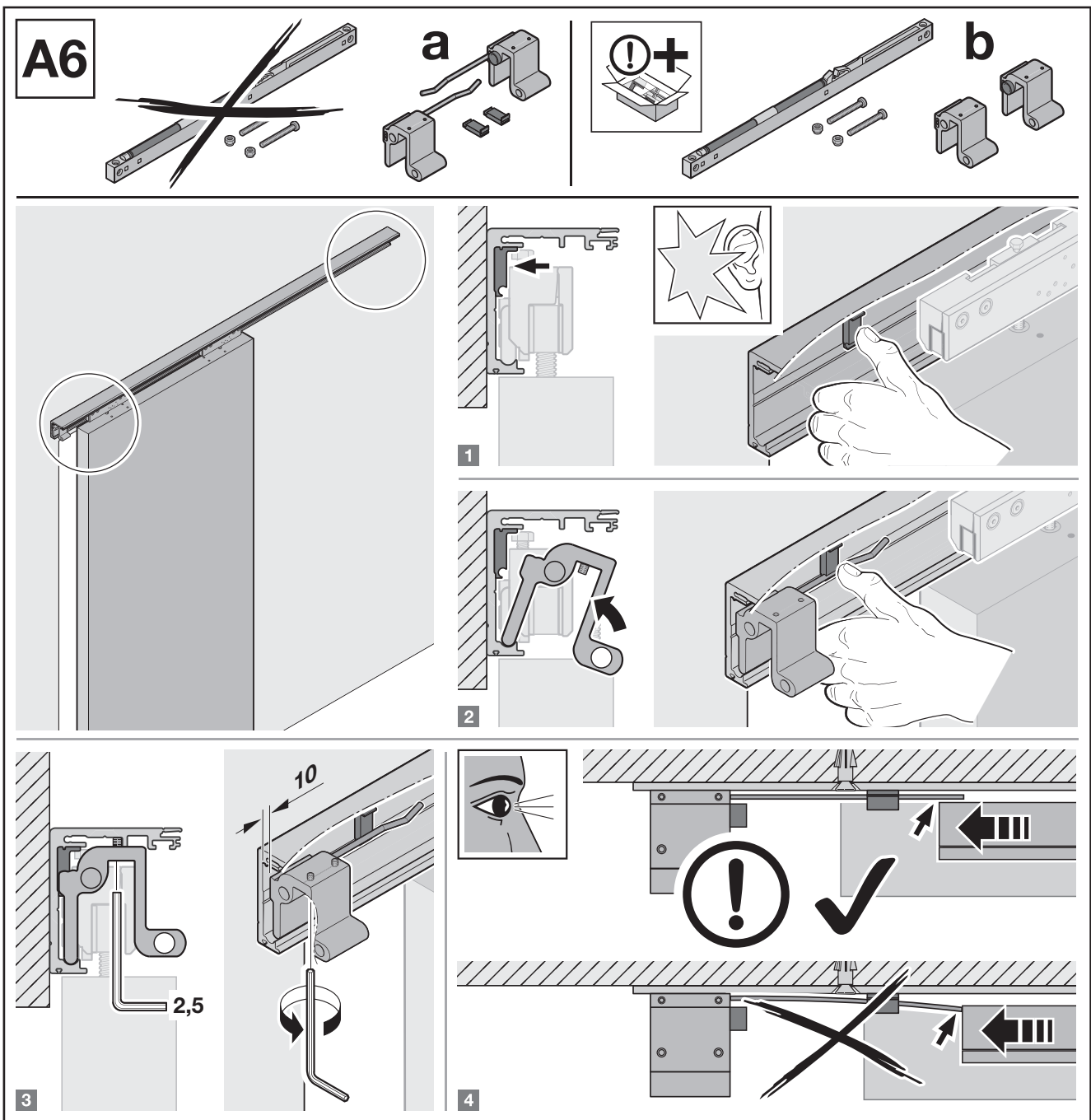
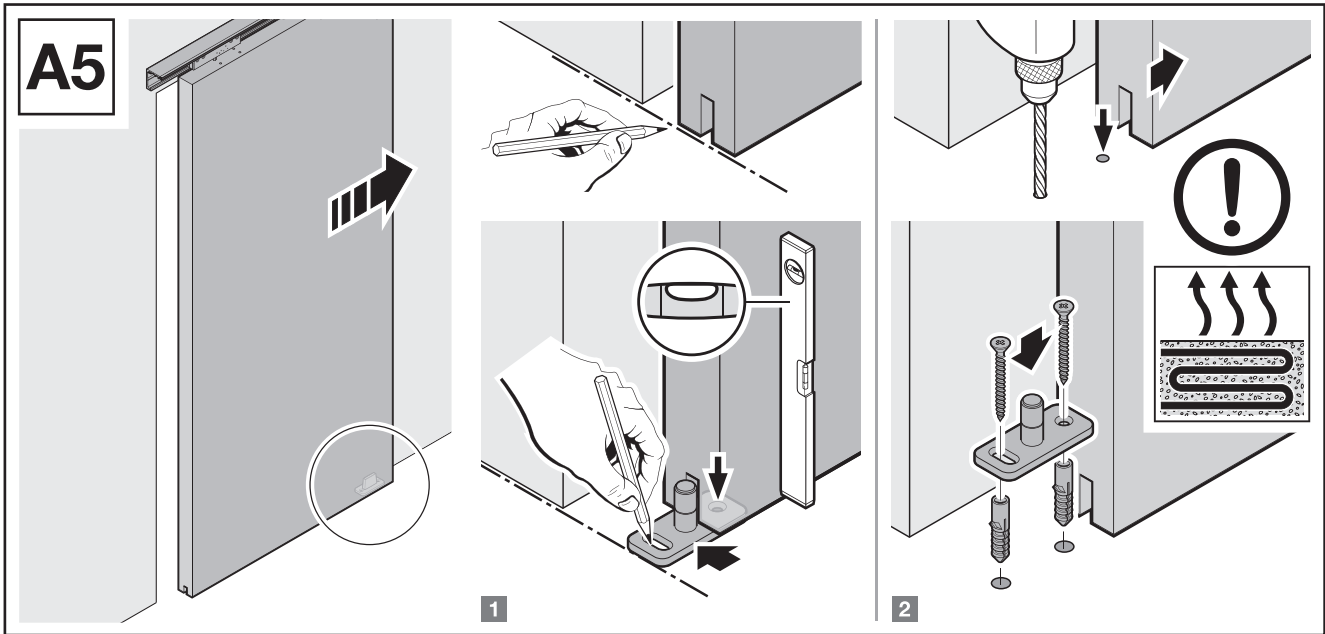



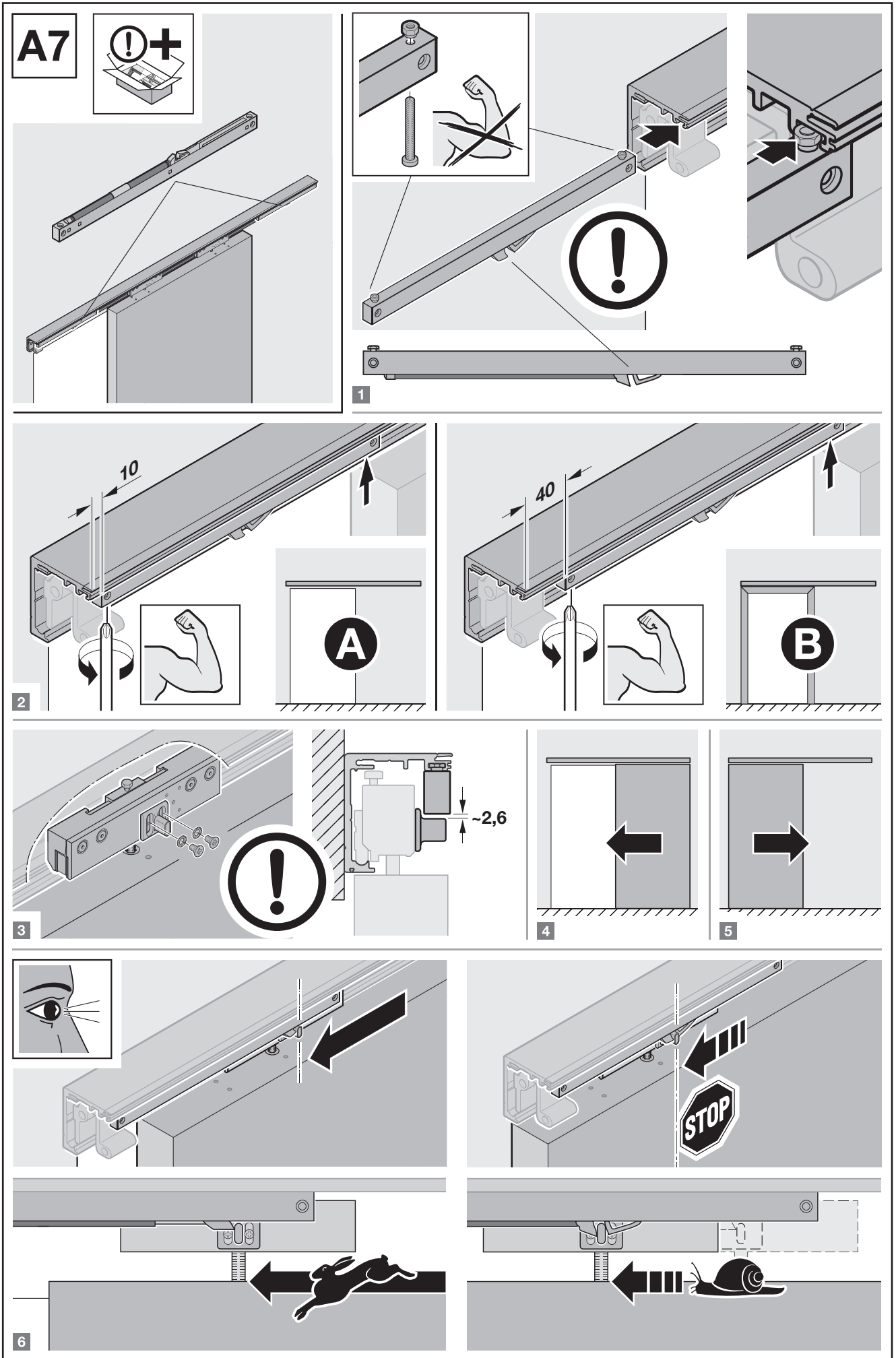



A8

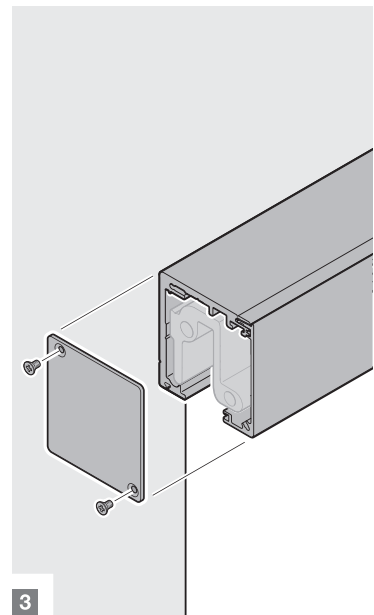
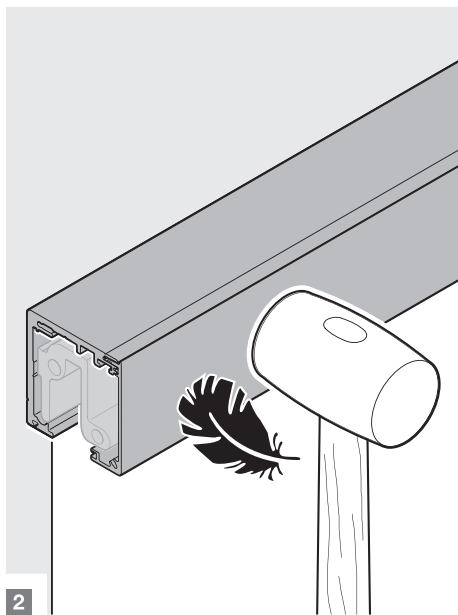
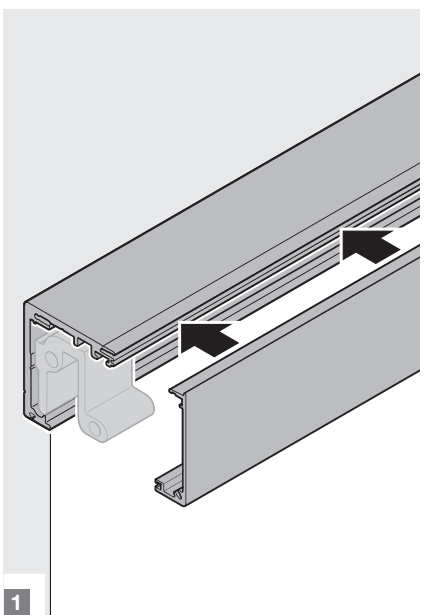
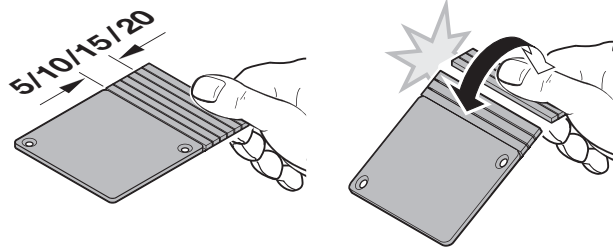
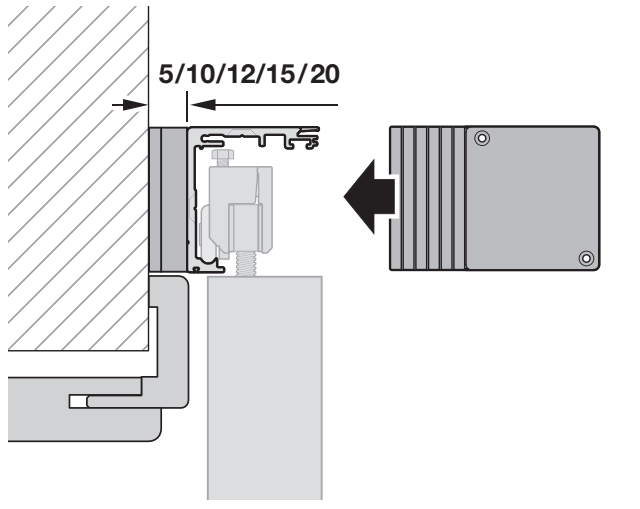
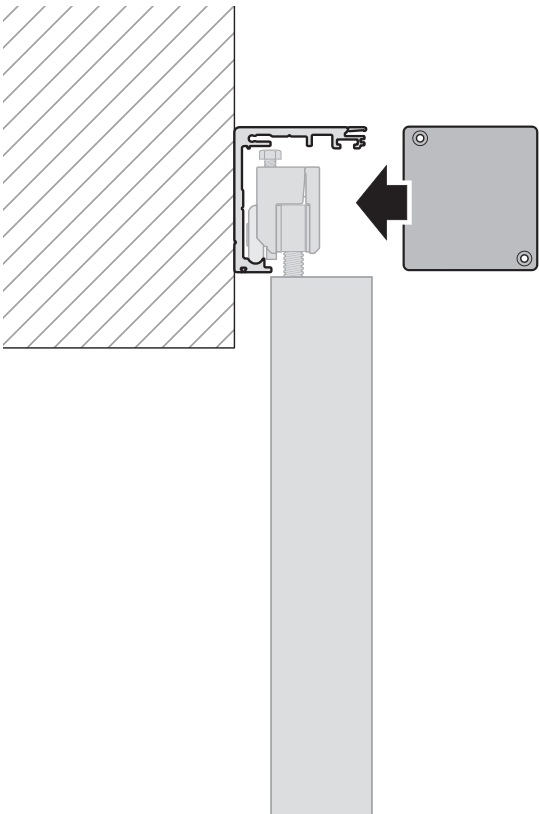
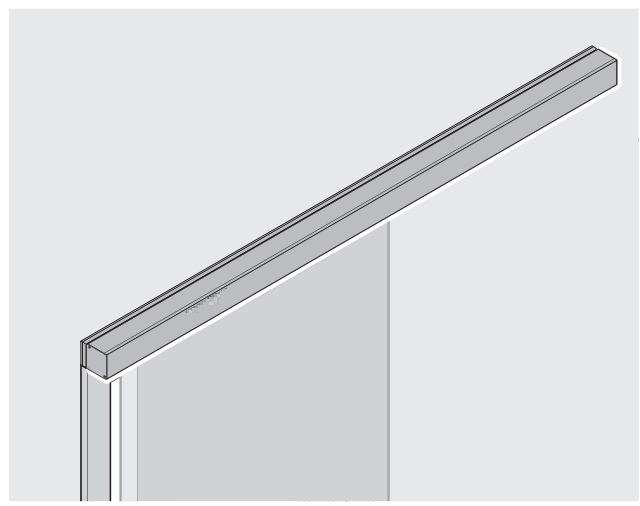
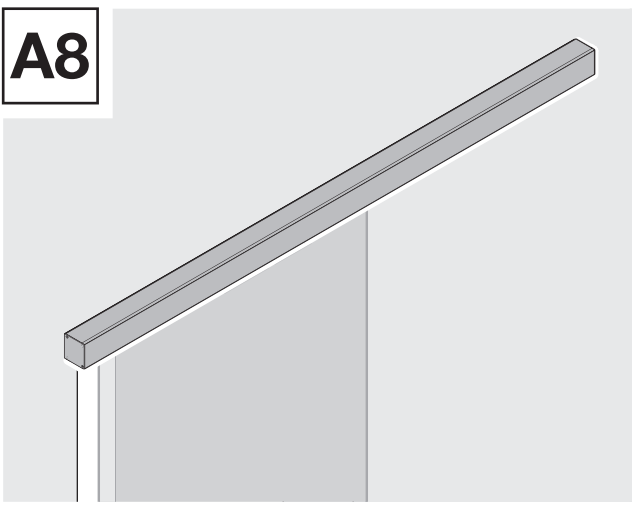

**B1**

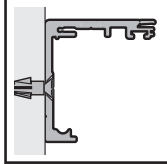
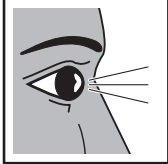

**A**

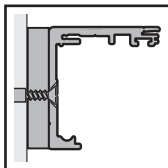
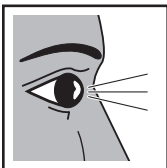
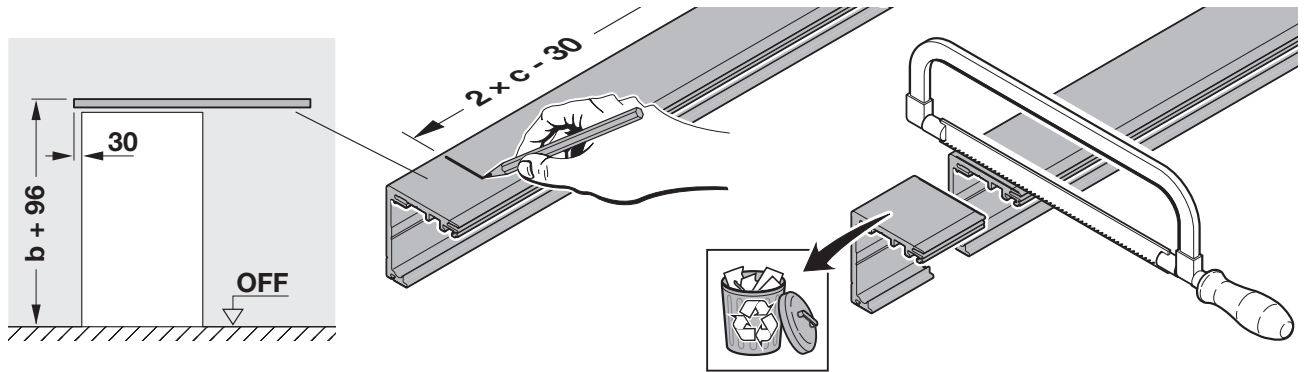
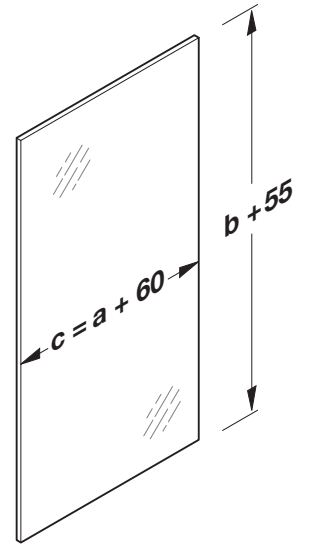
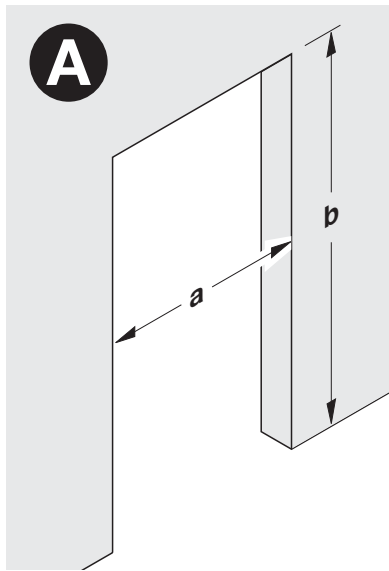
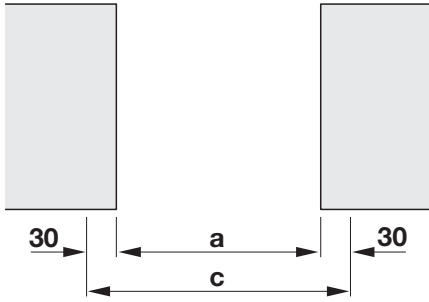

**B**

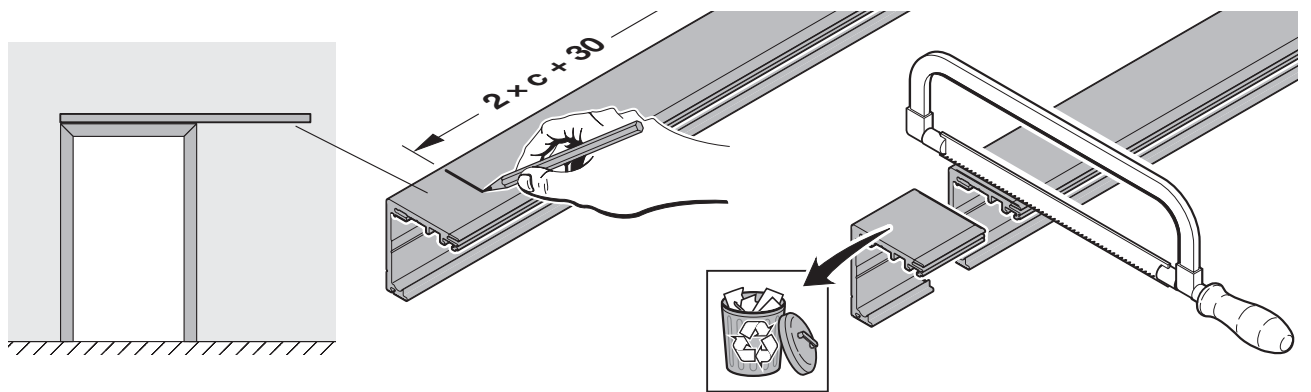
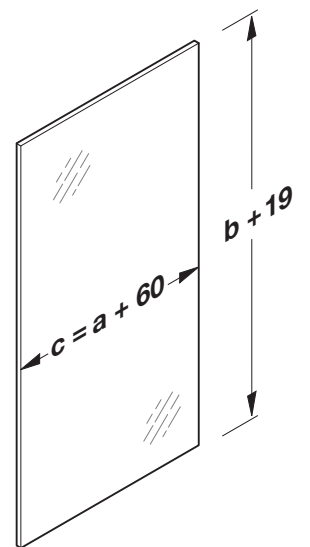
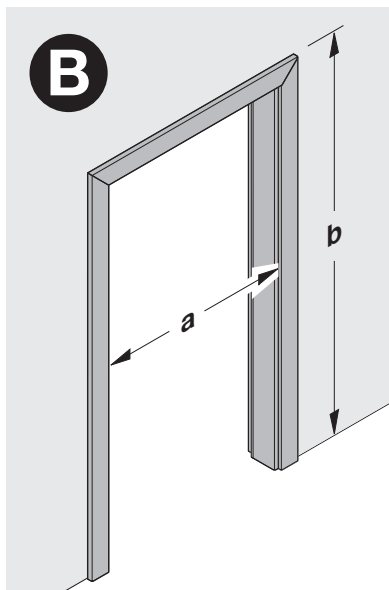
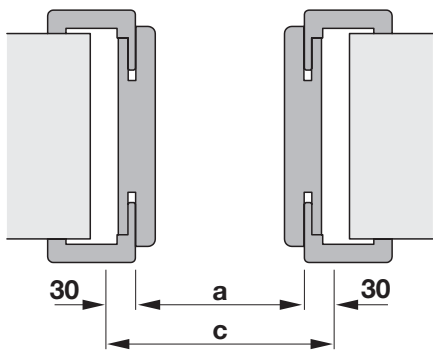

**B2**

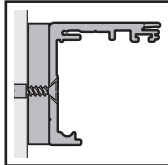
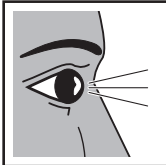

**B**

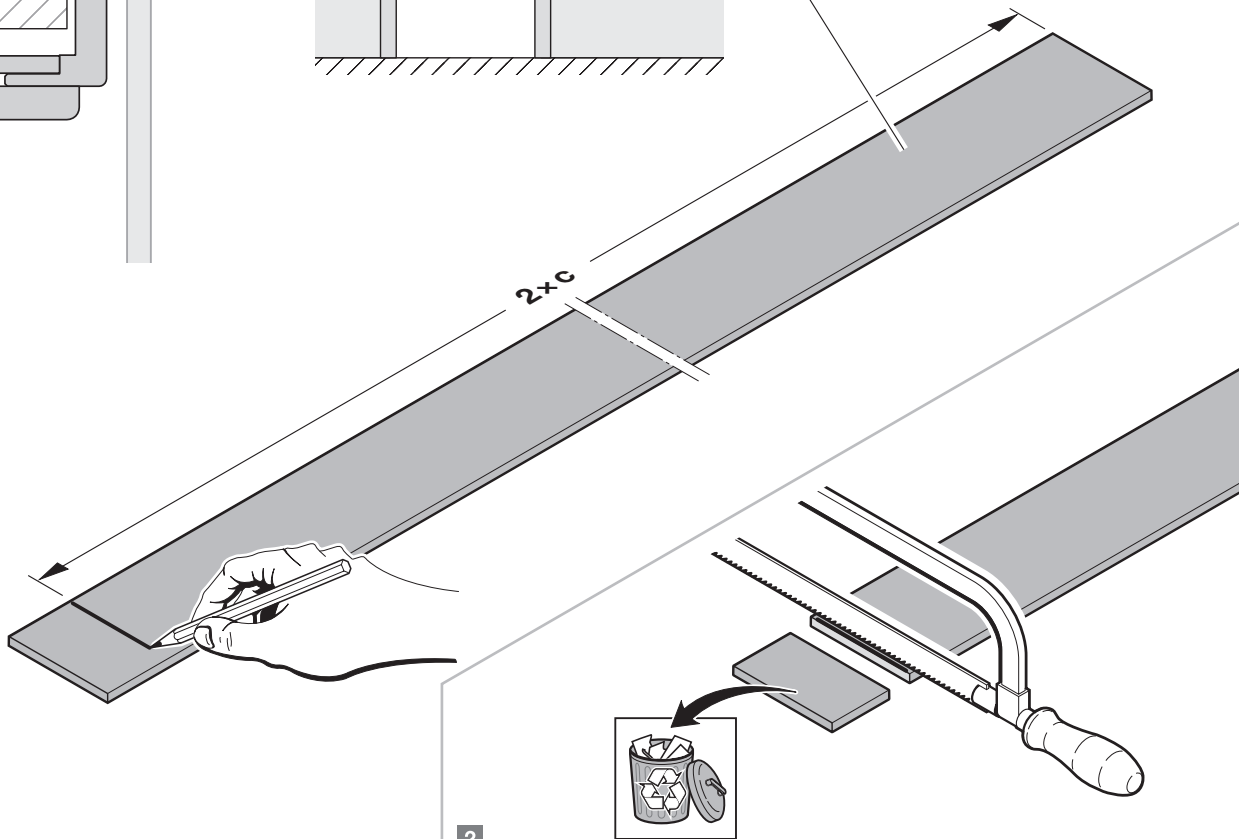
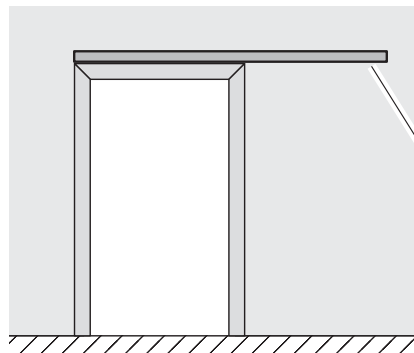
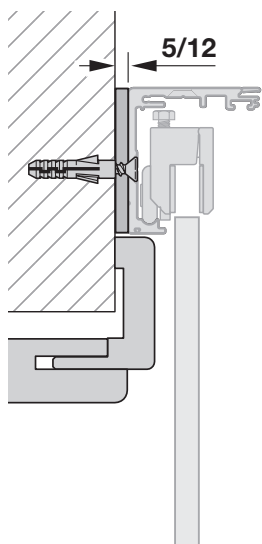
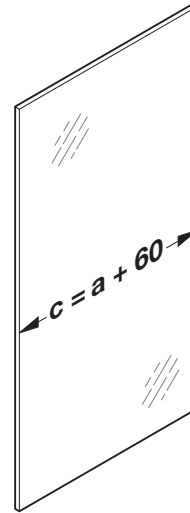
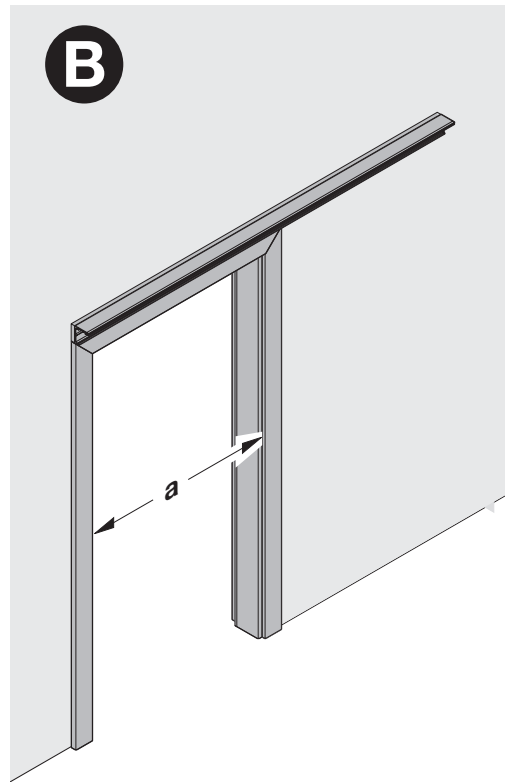
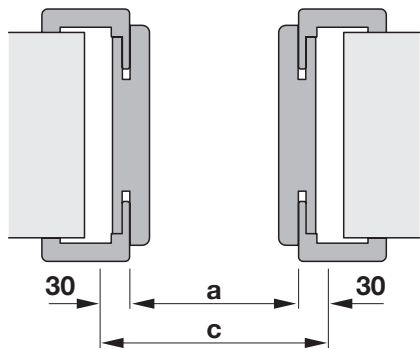

**1**

**2**

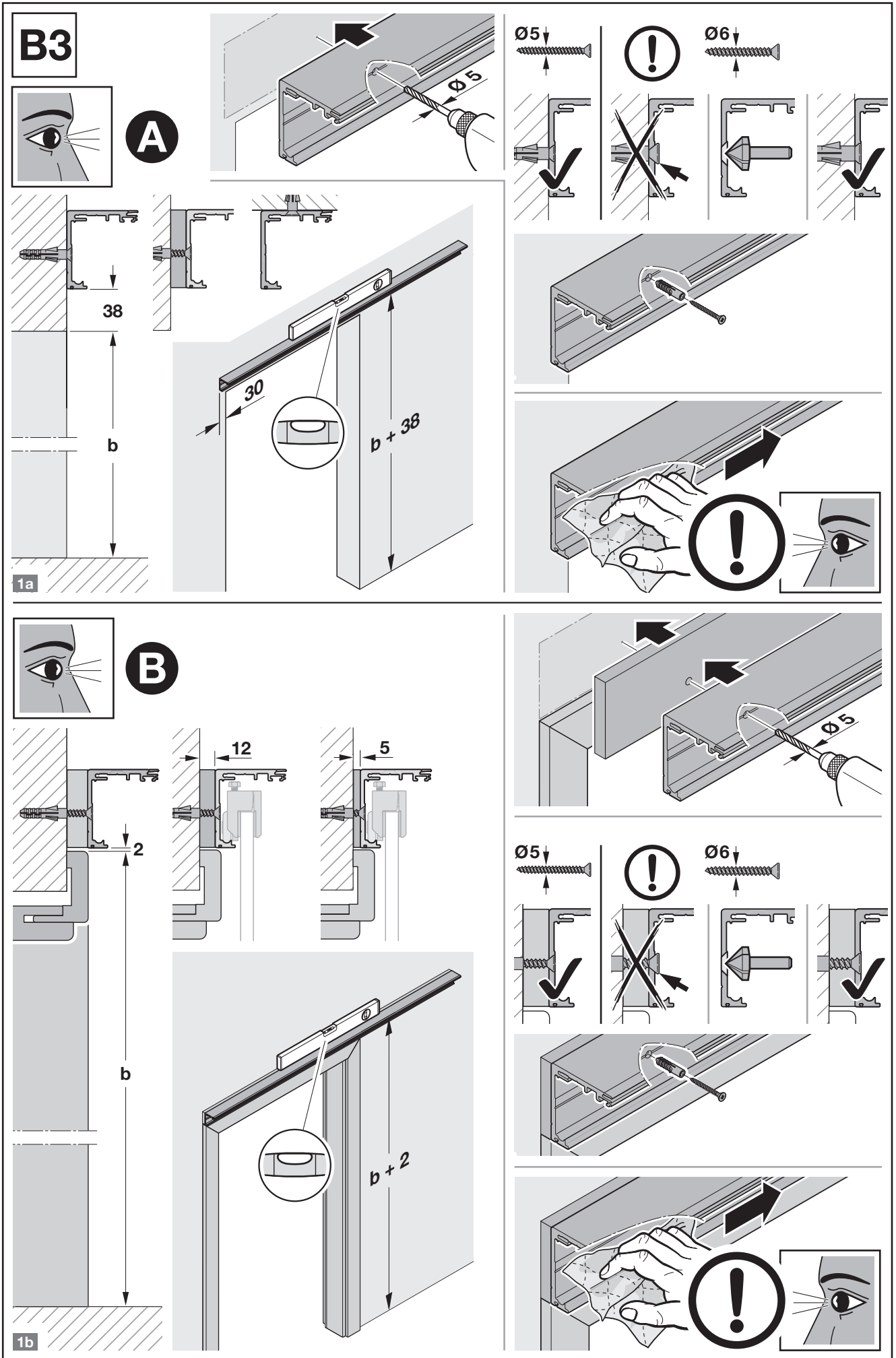

# B4

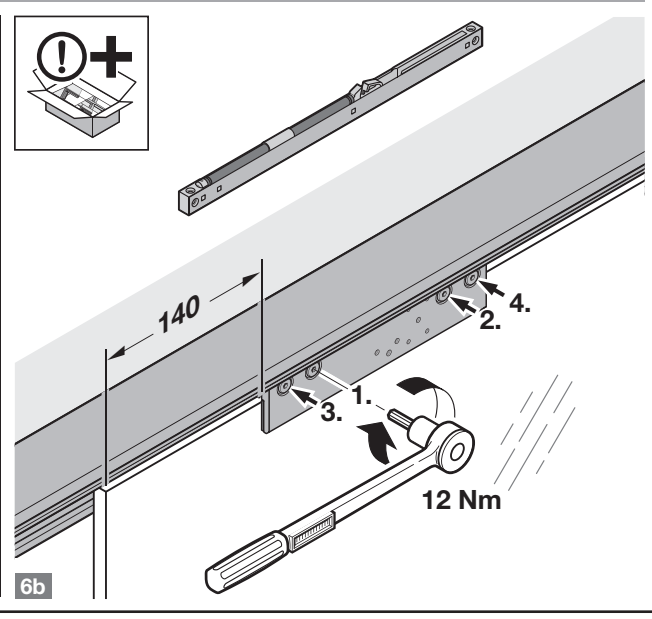
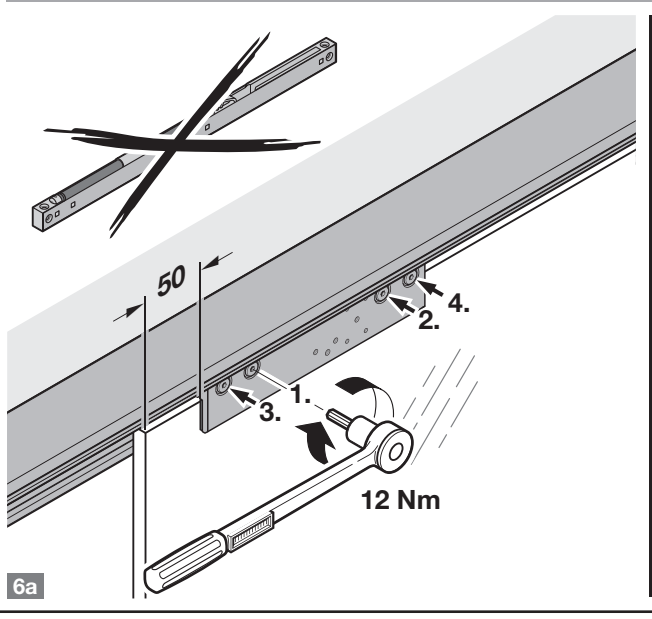
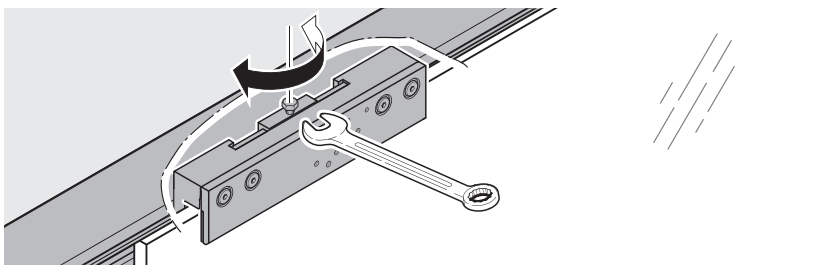
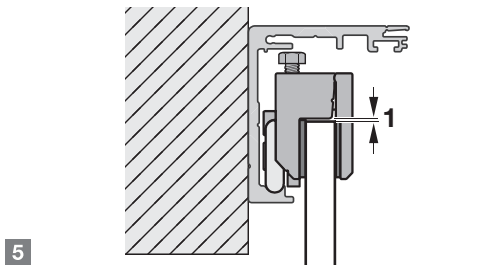
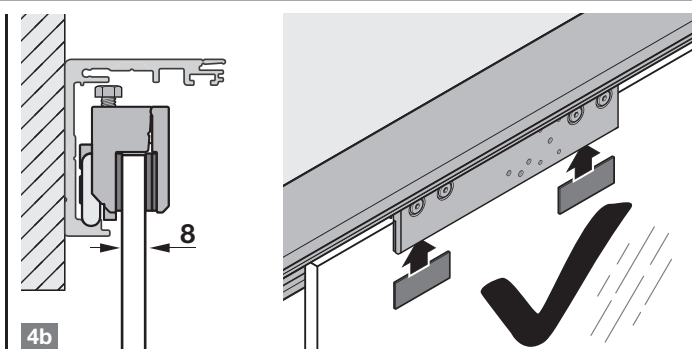
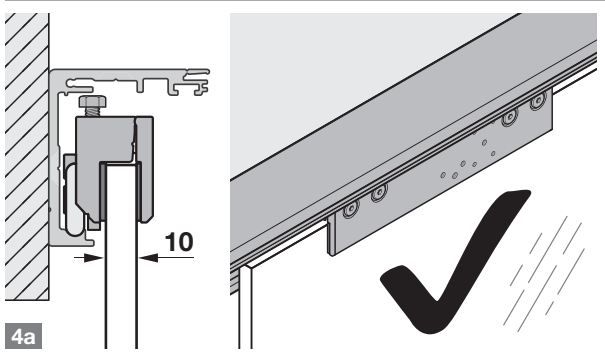
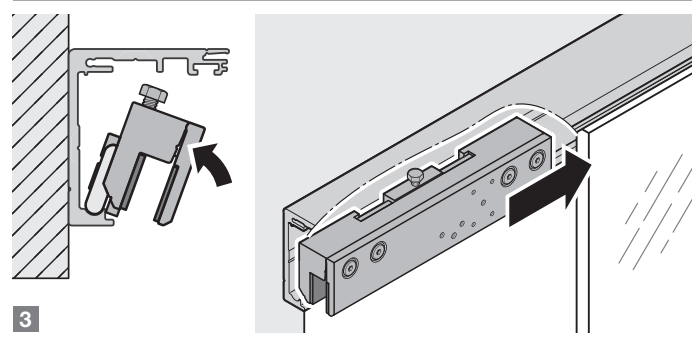
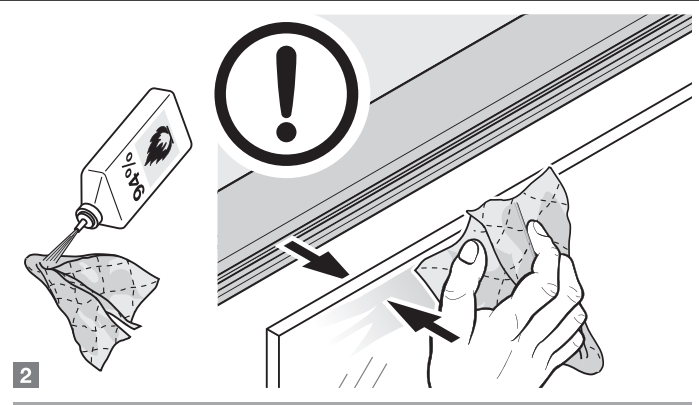
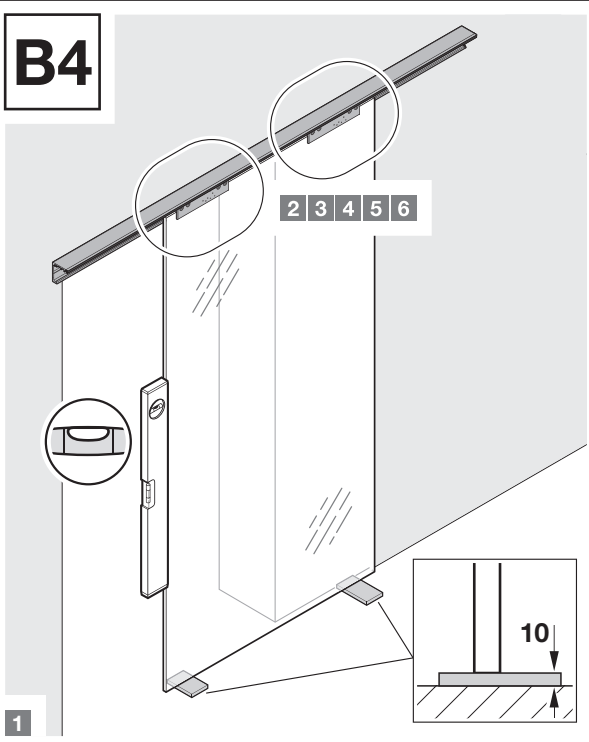

**B5**

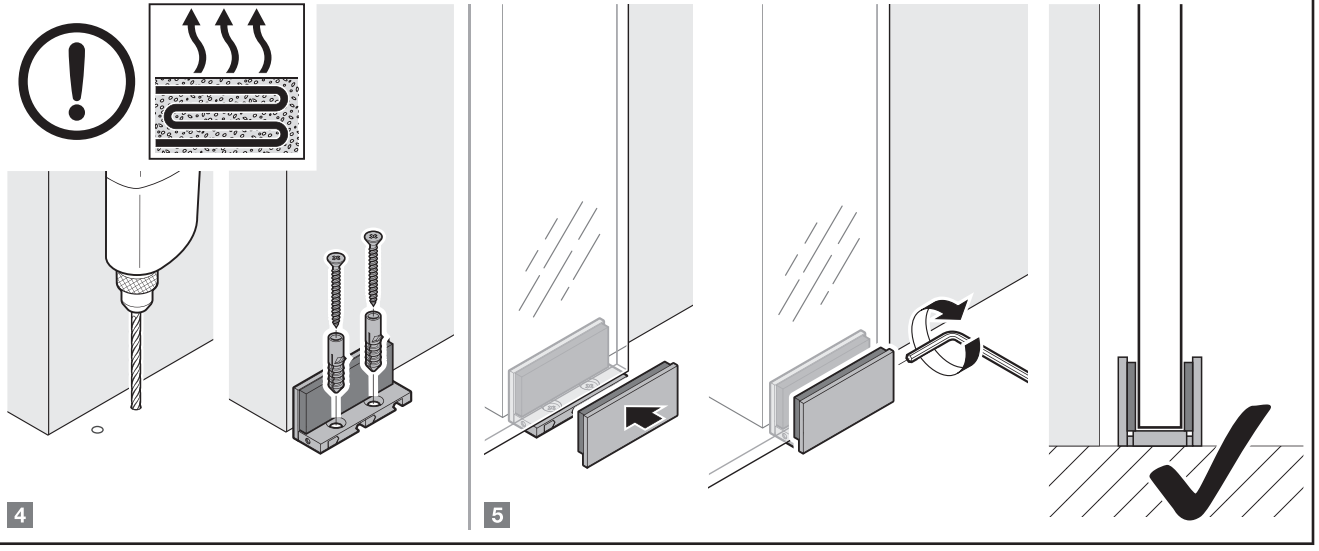
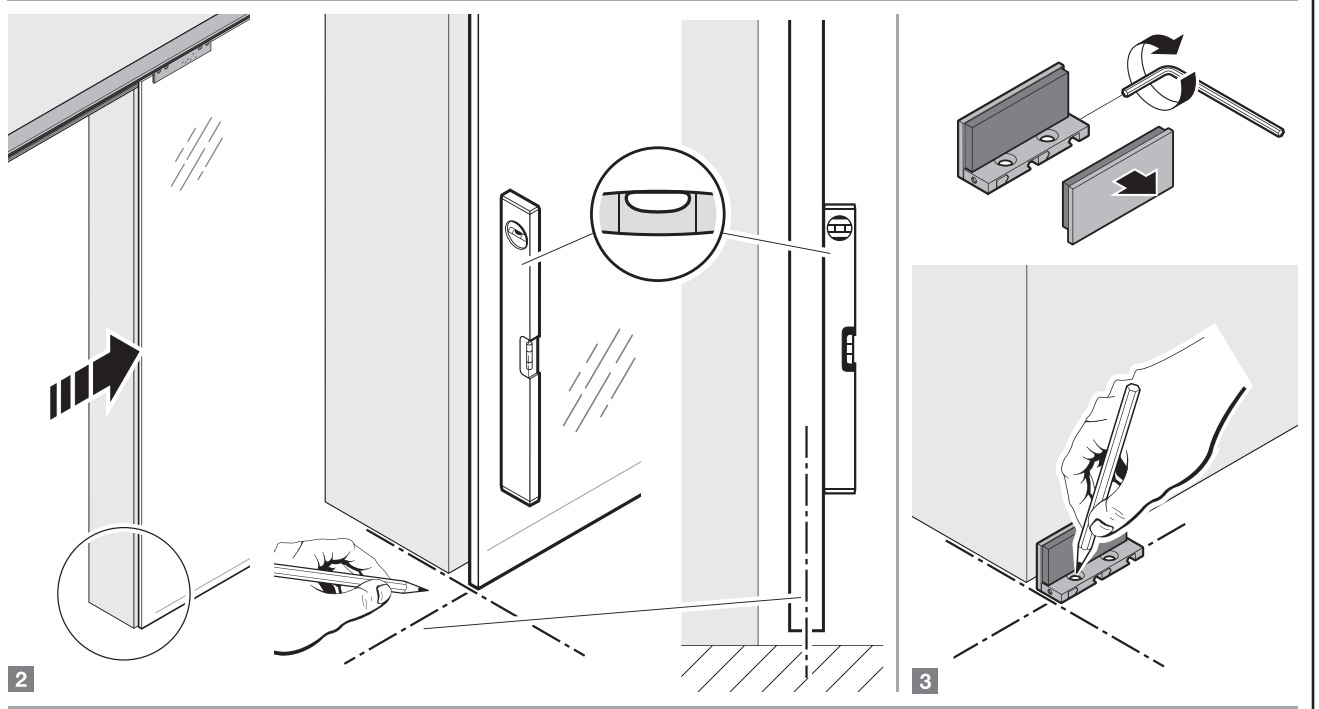
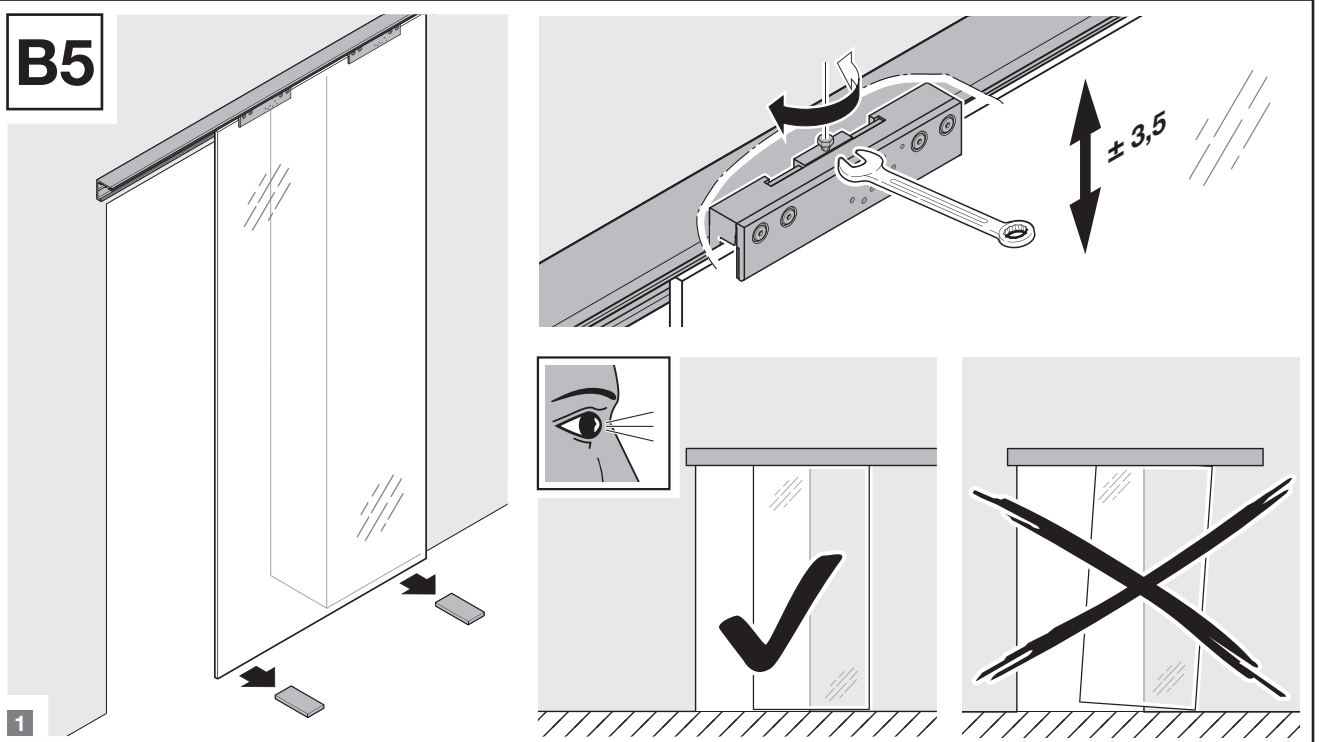

**B6**

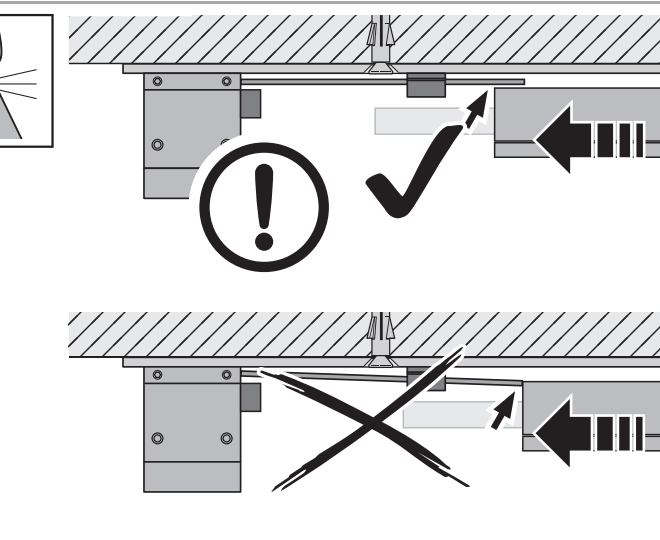
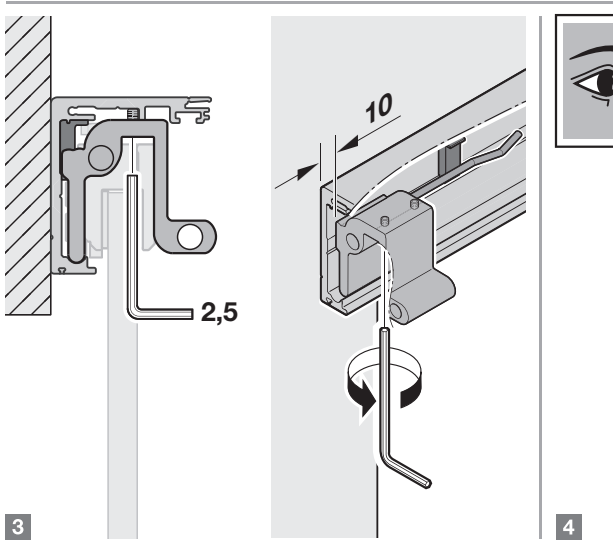
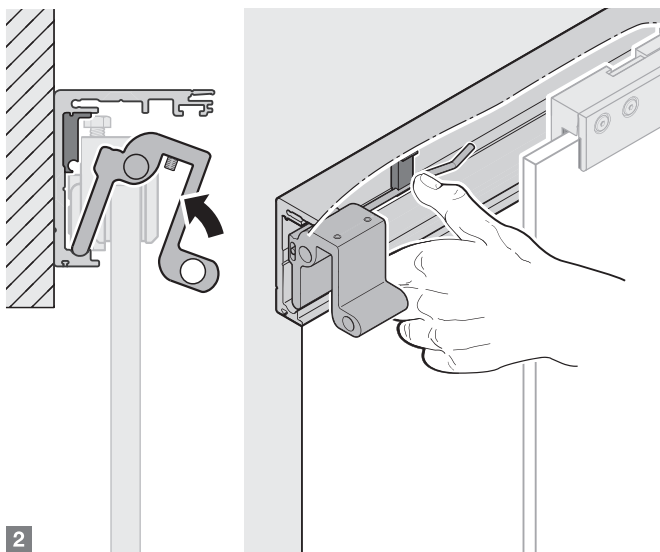
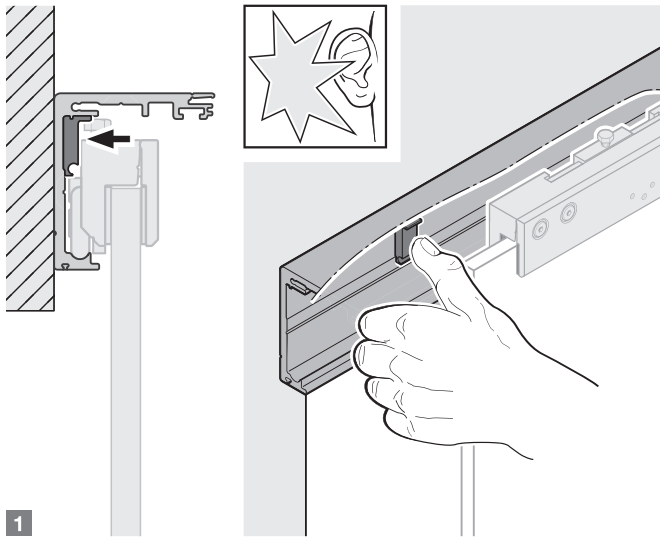
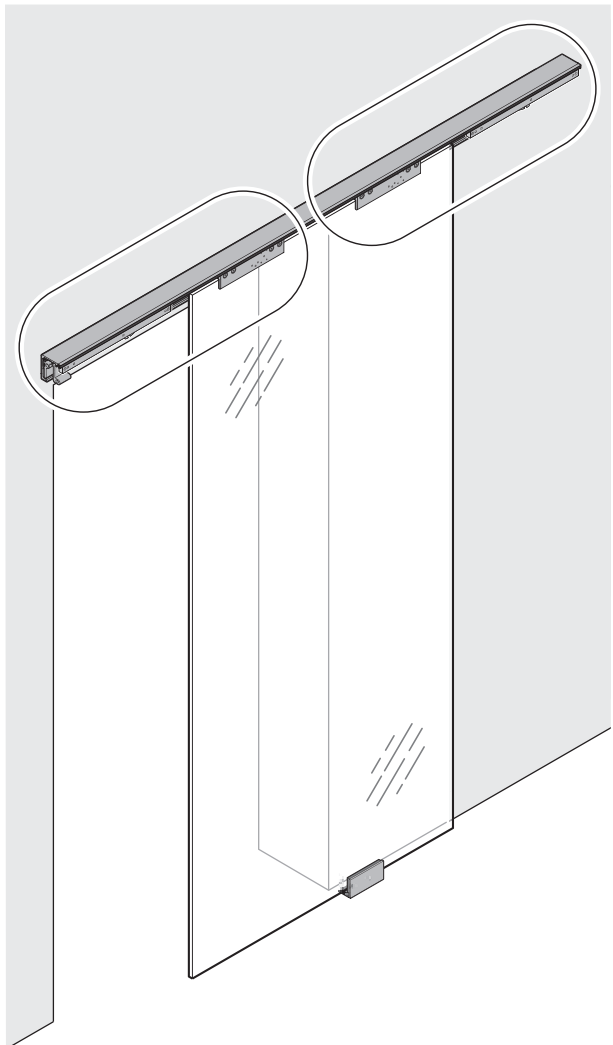
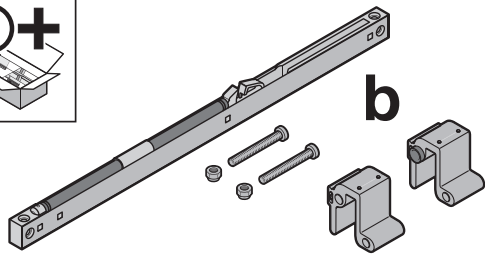
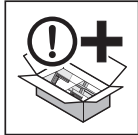
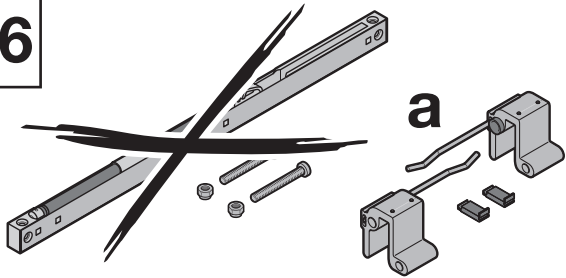

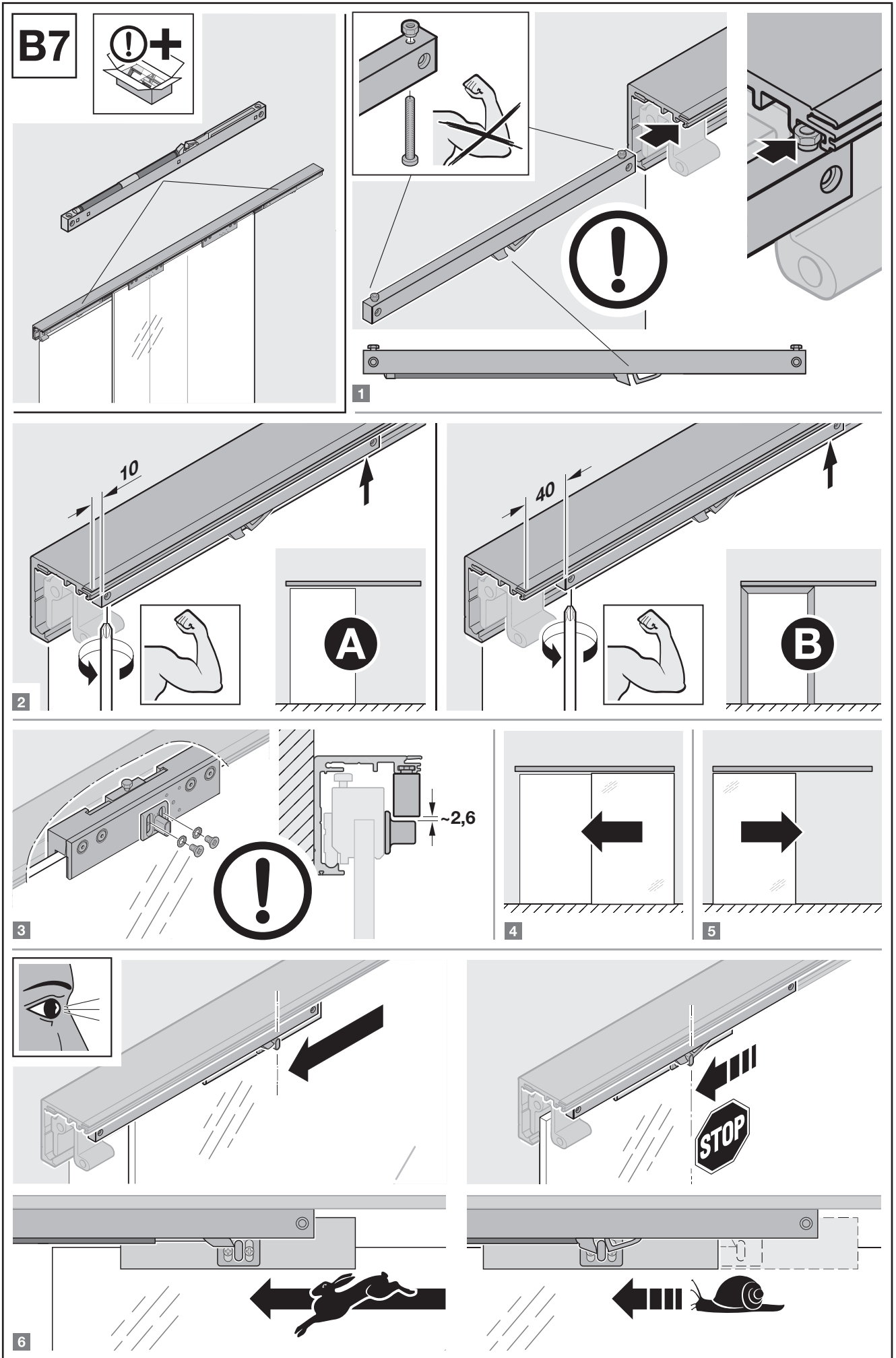



**B8**

